

Installation and Operating Instructions

Drillmat

February 1999

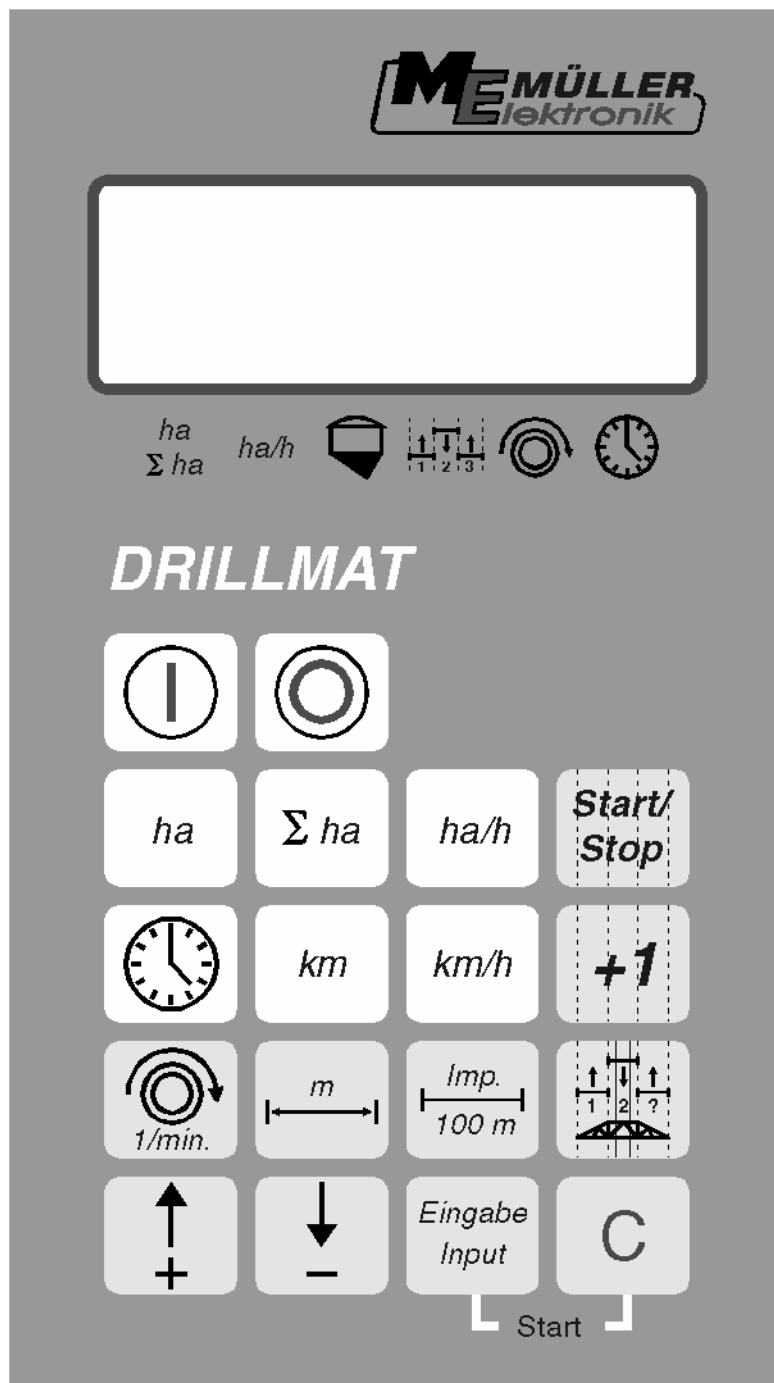

Read carefully before initial operation !

Contents

1	System description	3
1.1	Machine distributor.....	3
1.2	Computer	4
2	Installation instructions - Drillmat	5
2.1	Computer	5
2.2	12V plug connection to the tractor battery.....	5
2.3	Signal distributor - machine.....	5
2.4	Sensors.....	5
3	Safety	7
3.1	Specified implementation	7
3.2	Safety instructions.....	7
4	Operating instructions.....	8
4.1	Initial operation.....	8
4.2	Description of the entry keys.....	8
4.2.1	Setting keys +/-	8
4.2.2	"Working width" key	8
4.2.3	"Impulses/100m" key.....	9
4.2.4	"RPM" key "	9
4.2.5	"Tram line rhythm" key	10
4.2.6	"+1" key.....	11
4.2.7	"Start/stop" key	11
4.3	Description of the function keys	12
4.3.1	Device on/off	12
4.3.2	"Start function"	12
4.3.3	"Time" key.....	12
4.3.4	"Area" key	12
4.3.5	"Total area" key.....	13
4.3.6	"Current area output" key.....	13
4.3.7	"Distance" key.....	13
4.3.8	"Speed" key	13
4.4	Operation process.....	14
5	Maintenance	14
5.1	Computer	14
5.2	Sensors.....	14
6	Error recovery	15
6.1	The device does not switch on.....	15
6.1.1	The computer displays HALP 00 or HALP 88	15
6.2	The speed is not displayed	15
6.3	The area is not displayed.....	15

1 System description

The Drillmat is used to monitor the seed drill, to establish the working data and for tram line drilling.

The Drillmat essentially consists of:

- The board computer (installed in the cabin of the tractor) for the entry of the required data as well as serving as a monitor. In the case of a fault, an acoustic and optical alarm is set off.
- The machine distributor (installed on the frame of the Drillmat) with a connecting cable to the board computer.

With wheel sensor

Sensor for monitoring the drill shaft

Sensor for monitoring the fan

Level sensor

Track marker

1.1 Machine distributor

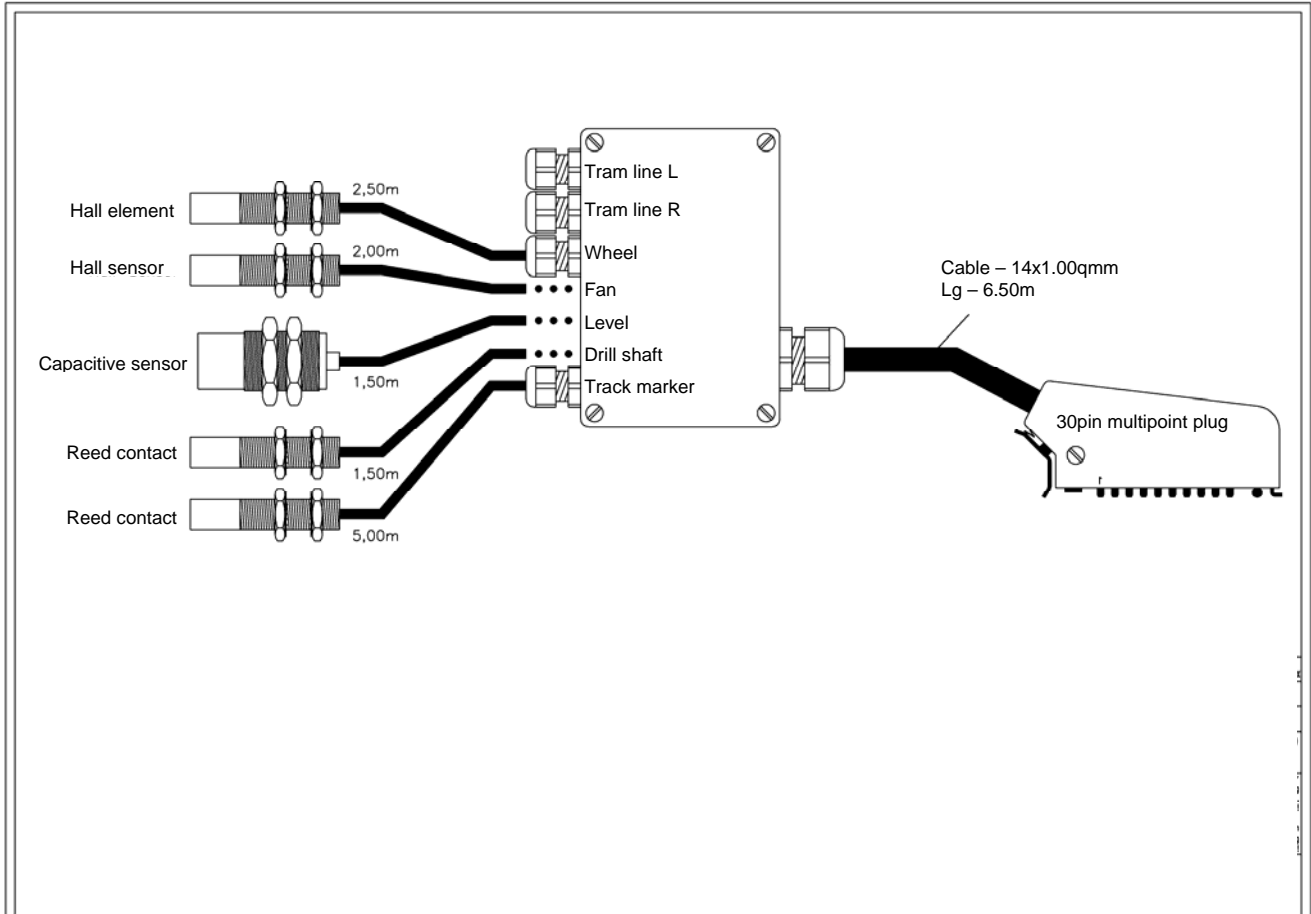

1.2 Computer

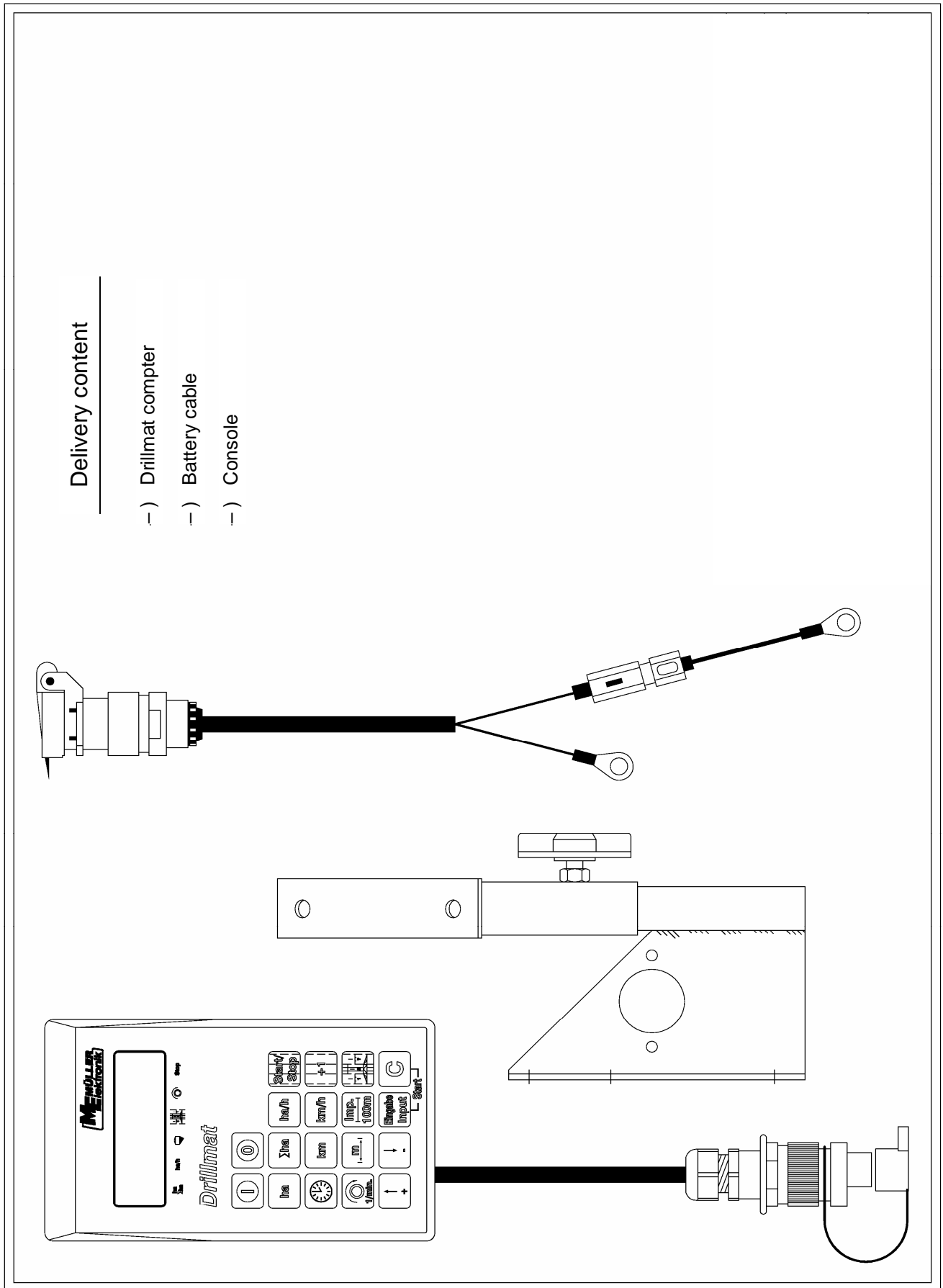

2 Installation instructions – Drillmat

2.1 Computer

The computer is to be installed together with the console within the driver's field of visibility. The distance from the radio equipment or radio antenna should be at least 1 m.

2.2 12V socket connection to the tractor battery

For the Drillmat's current supply (computer and sensors) the 12V socket supplied is to be connected to the tractor battery. No second device should be connected to this 12V socket. The 12V socket must be protected by a 25A safety fuse, which is to be found in the wire connector to the brown 12V wire.

Wire colours

brown = + 12 Volt
blue = ground

The battery's negative pole must always be at ground (frame, chassis).

2.3 Signal distributor machine

The signal distributor and the sensors are factory installed

2.4 Sensors

- Wheel sensor (Hall element)

With the wheel sensor the device determines the distance covered as well as the area.

The tube clip and magnet are mounted on to the wheel. The red side must point towards the sensor. The sensor is to be mounted to the fixture provided at a distance of 5-10 mm. A terminal block is provided for each lead in the machine distributor.

- Drill shaft sensor (Reed contact)

This sensor monitors the function of the drill shaft.

The tube clip and magnet are mounted on to the drill shaft. The red side must point towards the sensor. The sensor must be mounted to the fixture provided at a distance of approximately 20 mm.

- Level sensor (capacitive)

The sensor controls the seed bin.

As soon as the surface is no longer covered with grain, the sensor switches on and the computer sends out an alarm.

The sensor should be placed in the seed bin, so that it switches on as soon as the set amount of residue is reached. The end of the sensor should protrude 20 mm from the screw fitting.

The sensitivity can be regulated at the back of the sensor. When the sensor switches on, the lamp on the sensor lights up.

- Track marker (Reed contact)

The sensor indicates to the computer that the track markers have switched.

The sensor is to be mounted on to a static fixture opposite the switch mechanism for the track marker. The magnet is to be mounted on to the switch mechanism opposite the sensor at a distance of 20 mm. The magnet must momentarily be lead past the sensor when the track indicator switches. It's end position should not be in front of the sensor.

The tram line meter moves on one position each time the track marker switches on.

- Seed drill without track marker

The switch impulse is picked up when the top link is raised. The magnet and sensor should be mounted so that they approach each other in a raised position at roughly 20 mm.

In a working position the distance must be at least 40 mm.

- Fan sensor (Hall element)

Rpm monitor on the fan

Both magnets are to be mounted to the fixture provided. The red side must point towards the sensor. The sensor must be mounted at a distance of 5-10 mm to the sensors

3 Safety

3.1 Specified implementation

The Drillmat is specified exclusively for use in agriculture. Any application outwith this area is regarded as unspecified.

The manufacturer does not accept liability for damage to persons or property resulting from unspecified use. In such cases all risks are the responsibility of the user.

Specified implementation also includes adhering to the operation and maintenance conditions stipulated by the manufacturer in the operating instructions.

Relevant accident prevention regulations as well as other generally recognized safety, industrial-medical and road traffic rules are to be adhered to. In addition the manufacturer accepts no liability in cases where arbitrary modifications have been made to the Drillmat.

3.2 Safety instructions

Before working on the electrical system or carrying out any welding operations on the tractor or on an attached implement, the battery connection must be interrupted.

4 Operating instructions

4.1 Initial operation

The device carries out a self-test when switched on. After completion the function last used before switch-off is automatically selected.

In the case of an electrical fault the device displays:

HALP 00 or HALP 88

In this case return the device for repair.

4.2 Description of the entry keys

The keyboard has two colours:

White keys = function keys (display the recorded data)

Grey keys = entry keys (enter the machine data) and control keys

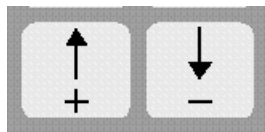

4.2.1 Setting keys +/-

When the + or – key is first pressed the display moves one position in the required direction.

Each time the key is pressed again, the display moves on until the key is let loose.

The board computer requires following machine data in order to be able to operate at all: Impulses/100m, working width, drill shaft rpm and the tram line rhythm.

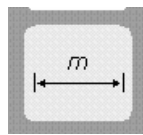

4.2.2 " Working width " key

This key is used to enter the actual working width

- Press " working width" key
- Select value using the +/- keys
- Press "enter" (=) key

Finally the value entered should be controlled once more by pressing the " working width" key.

4.2.3 " Impulses/100 m" key

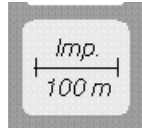

With this key the number of impulses recorded to the computer by the wheel sensor during a journey of 100 m are entered.

There are two possibilities to enter the data:

1. The impulses/100m value is known
 - Press "impulses/100m" key
 - Select value using the +/- keys
 - Press "enter" (=) key.
2. The impulses/100m value is not known
 - Measure out and mark a distance of 100 m on the field
 - Bring vehicle to the start position
 - Press "impulses/100m" and " C " key simultaneously
 - Travel a distance of 100 m
 - Press "enter" (=) key

4.2.4 "RPM" key



With the initial operation the rated rpm must be communicated to the computer.

The entry is to be carried out as follows:

- Start up the machine
- Press the "rpm" key
(current rpm will be displayed).
- Press "enter" (=) key

The value displayed at this moment in time is saved as the rated rpm

If monitoring is to be switched off, the following entry is required:

- Press the "rpm" key (display 0)
- Press "enter" (=) key
- Rpm monitoring is so switched off

The rpm alarm is displayed by a hooting sound and a flashing of the arrow above the rpm display every second. This occurs every 5 seconds with the drill shaft alarm.

4.2.5 "Tram line rhythm" key

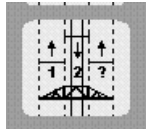

Tram lines can be laid out automatically using the Drillmat. For this purpose, the corresponding shares must be closed. The working width of the seed drill and the cultivator have to be taken into account. The tram line rhythm can be calculated from these values.

$$\text{Tram line rhythm} = \frac{\text{Working width of the cultivator}}{\text{Working width of the seed drill}}$$

Example: You are using a field sprayer with a working width of 24 m and a seed drill with a working width of 6 m. In this case the tram line rhythm is $24\text{m} : 6\text{m} = 4$.

The calculation results in even (2, 4, 6 etc.) and uneven (1, 3, 5 etc.) rhythms. In the case of even rhythms, the tram lines are usually laid out in 2 runs. As this tends to be more inaccurate, the even rhythms can be laid out in one run (S rhythms, e.g. 4S; 6S etc.) However, it has to be taken into consideration that the first run is carried out with half the working width of the seed drill and subsequently begins with position 1 of the rhythm.

Following rhythms are supported by the Drillmat:

No.	Rhythm	Tram line	No.	Rhythm	Tram line
0	No rhythm	0	2-S	2s	1
2	2	1, 2	4-S	4s	2
3	3	2	6-S	6s	3
4	4	2, 3	8-S	8s	4
5	5	3	10-S	10s	5
6	6	3, 4	12-S	12s	6
7	7	4			
8	8	4, 5			
9	9	5			
10	10	5, 6			
11	11	6			
12	12	6, 7			
14	14	7, 8			
		Tram line left			Tram line right
15	10 (20m/8m, 15/6m) beginning on the right	2; 9			4; 7
16	10 (20m/8m, 15/6m) beginning on the left	4; 7			2; 9
18	18 (18m/4m, 27/6m) beginning on the left	3; 16			7; 12
19	10 (18m/4m, 27/6m) beginning on the right	7; 12			3; 16

To adjust the tram line rhythm press the tram line rhythm key. The correct rhythm is then set with the +/- setting keys. Finally the new rhythm is confirmed with the enter key.

If the correct tram line rhythm has been adjusted and set to 1, the side of the field where work is to begin still has to be taken into account. With uneven and S rhythms, work can begin on either side of the field. With the even rhythms 4, 8 and 12, work must begin at the side where the closed share is, and with rhythms 6, 10 and 14 on the opposite side of the field.

In the case of the special rhythms, no. 15, 16, 18, 19 the side of the field where work is to begin must be determined first. "Beginning on the left" means that the side of the field when starting lies on the left hand side of the tractor in the direction of travel. Consequently, "beginning on the left" is the other way round.

4.2.6 "+1" key

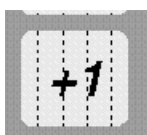

With this key the tram lines can be switched on further manually by one step at a time.

4.2.7 "Start/Stop" key



With this key the automatic relaying of the tram line rhythm can be stopped and released again.

When stopped, the arrow above the tram line symbol flashes !

4.3 Description of the function keys

4.3.1 Device on/off



The device is switched on by pressing the On (I) key.
Switch off with the Off (O) key.

Should the voltage supply drop to below 9 volt, e.g. when starting the tractor, the computer switches off automatically. It can be switched on again by pressing the On key.

4.3.2 "Start function"

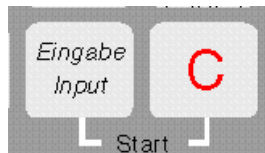

The start function is released by pressing the "=" and "C" keys simultaneously. That means that the memory for the area, time and distance is set to 0. The time is restarted automatically by pressing this key. This function is to be carried out at the beginning of each operation.

4.3.3 "Time" key



The operating time since carrying out the "start function" (see 4.3.2) is displayed by pressing this key. If the tractor is switched off and the computer voltage-free, the time data entry is stopped. It restarts once the device is switched on again. The clock can also be stopped during operation. After the "time" key has been pressed, it can be pressed once again to stop the clock. To restart it, the "time" key has to be pressed yet again.

4.3.4 "Area" key



The area covered since carrying out the "start function" (see 4.3.2) is displayed by pressing this key. Measurement is interrupted as soon as the computer stops receiving wheel impulses.



4.3.5 "Total area" key

With this key the total area for a whole season can be determined. The memory is set to 0 at the beginning of the season by pressing the "total area" and "C" keys simultaneously.



4.3.6 "Current area output" key

With this key the current area output is displayed in ha/h.



4.3.7 "Distance" key

The distance covered since carrying out the "start function" (see 4.3.2) is displayed by pressing this key.

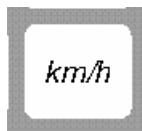

4.3.8 "Speed"

When this key is pressed the current speed travelled is displayed.

4.4 Operation process

Once the machine data have been entered, the following steps have to be carried out before beginning operation. The track marker at the beginning of the field is to be operated so that the right side is lowered.

Subsequently only the start function has to be carried out (see 4.3.2).

After that, each time the end of the field is reached and the track marker switched, tram line drilling is continued automatically. Even when the computer is switched off temporarily, the last position is stored. When the computer is switched on again, the last setting is available once more. Drilling can begin again immediately.

During the operation process the area, total area, operating time, distance are determined and the speed and output displayed.

5 Maintenance

5.1 Computer

The computer is maintenance-free. During the winter it should be stored at room temperature.

5.2 Sensors

The sensors are maintenance-free

6 Error recovery

When trouble shooting keep to the intended sequence!

Error	Cause	Measures
6.1 The device does not switch on	Polarity reversal of the voltage supply	Check polarity
	Voltage supply interrupted	Check battery connection cable; control battery clamps and fuse
	Total failure	Send in device
6.1.1 The computer displays HALP 00 or HALP 88	Memory error	Send in device
6.2 Speed is not displayed	Impulses/100m not entered	Enter number of Impulses/100m (see 4.2.3.)
	The wheel sensor is not sending any impulses to the computer, the ring in the display is not flashing during the journey.	Adjust the distance of the wheel sensor to the magnet to 5-10mm.
		The red side of the magnet must point towards the sensor.
		Secure magnet with a non-magnetic screw.
		Connect cable in the distributor correctly green = gn = signal brown = br = + 12 volts white = ws = 0 volt
		Sensor is defective, replace
		Computer is defective, replace
		Distributor is defective, replace
6.3 The area is not displayed	Working width not entered	Enter working width (see 4.2.2.)